



# FUJII ELECTRIC

## SPLIT TYPE ROOM AIR CONDITIONER

### WALL MOUNTED type

# SERVICE MANUAL

Models	Indoor unit	Outdoor unit
	RSW-14CA	ROW-14AA
	RSW-14HA	ROW-14RA
	RSW-17CA	ROW-17CA
	RSW-17HA	ROW-17RB

## C O N T E N T S

SPECIFICATIONS .....	1
DIMENSIONS .....	2
REFRIGERANT SYSTEM DIAGRAM .....	3
CIRCUIT DIAGRAM .....	5
P.C. BOARD LAYOUTS .....	9
INDOOR PRINTED CIRCUIT BOARD CIRCUIT DIAGRAM .....	10
DISASSEMBLY ILLUSTRATION .....	13
PARTS LIST .....	19



Большая библиотека технической документации

<https://splitsystema48.ru/instrukcii-po-ekspluatácii-kondicionerov.html>

каталоги, инструкции, сервисные мануалы, схемы.

# SPECIFICATIONS

INDOOR UNIT		RSW-14CA	RSW-14HA	RSW-17CA	RSW-17HA
OUTDOOR UNIT		ROW-14AA	ROW-14RA	ROW-17CA	ROW-17RB
COOLING CAPACITY	(kW)	3.85 - 4.00	3.85 - 4.00	4.75 - 4.90	4.70 - 4.80
HEATING CAPACITY	(kW)	—	4.65 - 4.80	—	5.00 - 5.15

## ELECTRICAL DATA

POWER SOURCE	(V)	220 - 240			
FREQUENCY	(Hz)	50			
RUNNING CURRENT	COOLING	6.9 - 7.0	6.7 - 6.8	8.0 - 7.8	9.5 - 10.0
	HEATING	—	7.6 - 7.8	—	9.9 - 10.5
INPUT WATTS	COOLING	1.48 - 1.55	1.44 - 1.53	1.75 - 1.85	1.98 - 2.15
	HEATING	—	1.62 - 1.70	—	2.10 - 2.25
E.E.R.	COOLING	2.60 - 2.58	2.67 - 2.61	2.71 - 2.65	2.37 - 2.23
	HEATING	—	2.87 - 2.82	—	2.38 - 2.29
MOISTURE REMOVAL	(ℓ/hr)	1.6	1.6	2.1	2.1
AIR CIRCULATION-HI	(m <sup>3</sup> /hr)	540	540	540	560

## COMPRESSOR

TYPE	Hermetic type, Permanent split condenser, 2 pole, Single phase, Induction motor		
CODE	QJ282PC24A	2JS318D5BA02	2JS350D5AB02

## FAN MOTOR

		INDOOR UNIT		OUTDOOR UNIT		INDOOR UNIT		OUTDOOR UNIT	
MODEL		RSW-14CA	RSW-14HA	ROW-14AA	ROW-14RA	RSW-17CA	RSW-17HA	ROW-17CA	ROW-17RB
TYPE		MFA-17AT		MFB-14VTT		MFA-17AT		MFB-247FBT	
POWER SOURCE		220 - 240		220 - 240		220 - 240		220 - 240	
FAN SPEED	HI-SPEED	1,240		750	750	1,240	1,300	740	735
	MED-SPEED	1,160				1,160	1,210		
	LO-SPEED	1,080				1,080	1,110		

## DIMENSIONS

HEIGHT x WIDTH x DEPTH	(mm)	285 x 900 x 172	530 x 750 x 250	285 x 900 x 172	643 x 840 x 336
------------------------	------	-----------------	-----------------	-----------------	-----------------

## WEIGHT

GROSS / NET	(mm)	13 / 10	38 / 36	39 / 37	13 / 10	63 / 55	67 / 59
-------------	------	---------	---------	---------	---------	---------	---------

## REFRIGERANT CHARGE

PIPE LENGTH		16 ft ( 5 m )	23 ft ( 7 m )	33 ft ( 10 m )	49 ft ( 15 m )	66 ft ( 20 m )
FULL CHARGE AMOUNT	RSW-14CA	38.4oz (1,090g)	39.9oz (1,130g)	42.0oz (1,190g)	—	—
	RSW-14HA	38.8oz (1,100g)	40.2oz (1,140g)	42.3oz (1,200g)	—	—
	RSW-17CA	45.9oz (1,300g)	47.3oz (1,340g)	49.4oz (1,400g)	52.9oz (1,500g)	56.4oz (1,600g)
	RSW-17HA	54.0oz (1,530g)	54.6oz (1,550g)	55.7oz (1,580g)	57.4oz (1,630g)	59.3oz (1,680g)

Note : Between 5 m and 20 m, when using a connection pipe other than that in the table, charge additional refrigerant with 0.7 oz (20 g) / 3.3 ft (1 m) for RSW-14CA, RSW-14HA, RSW-17CA and 0.4 oz (10 g) / 3.3 ft (1 m) for RSW-17HA as the criteria.

# DIMENSIONS

## INDOOR UNIT

Models : RSW-14CA, RSW-14HA,  
RSW-17CA, RSW-17HA

(unit : mm)

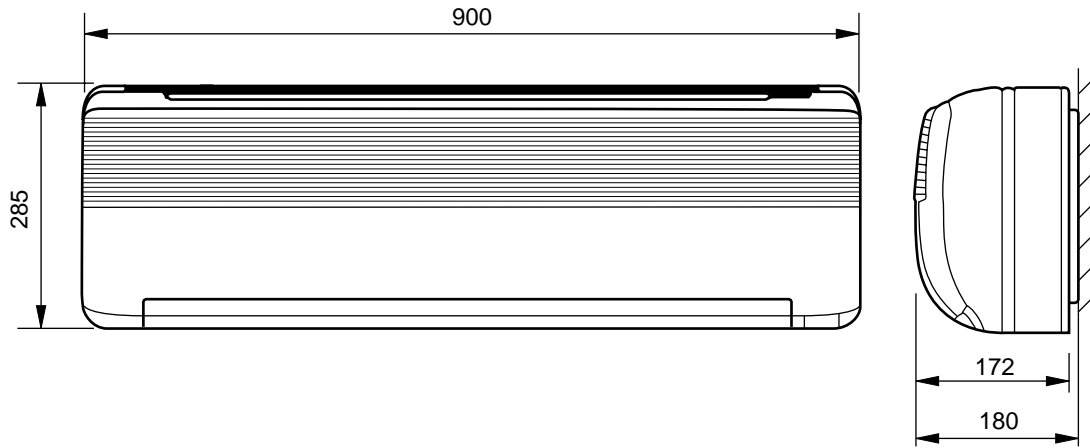

## OUTDOOR UNIT

Models : ROW-14AA, ROW-14RA

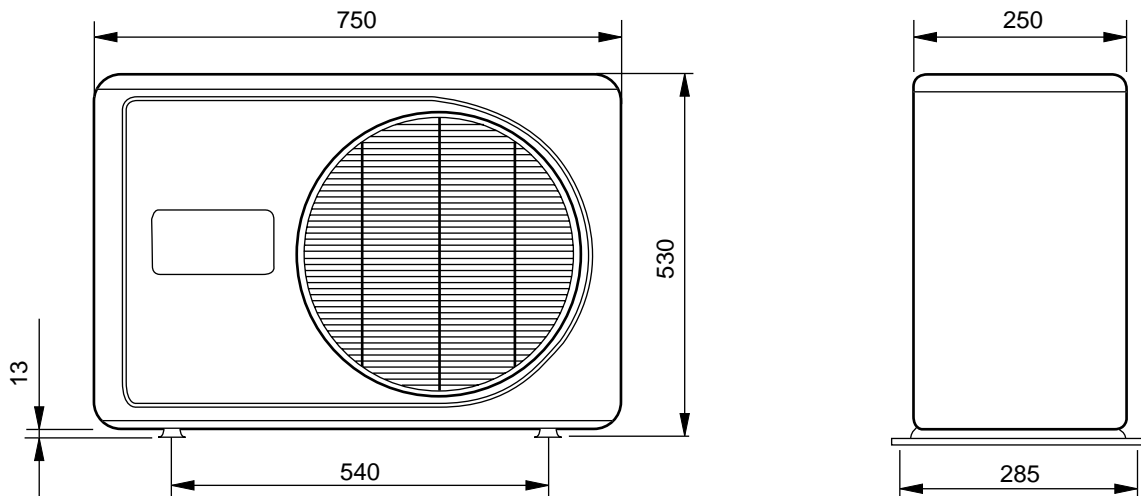

Models : ROW-17CA, ROW-17RB

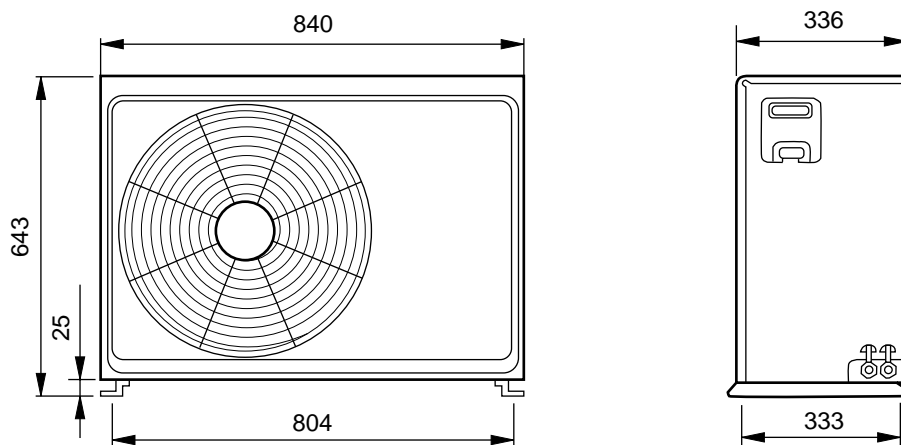

# REFRIGERANT SYSTEM DIAGRAM

**Models : RSW-14CA / ROW-14AA**

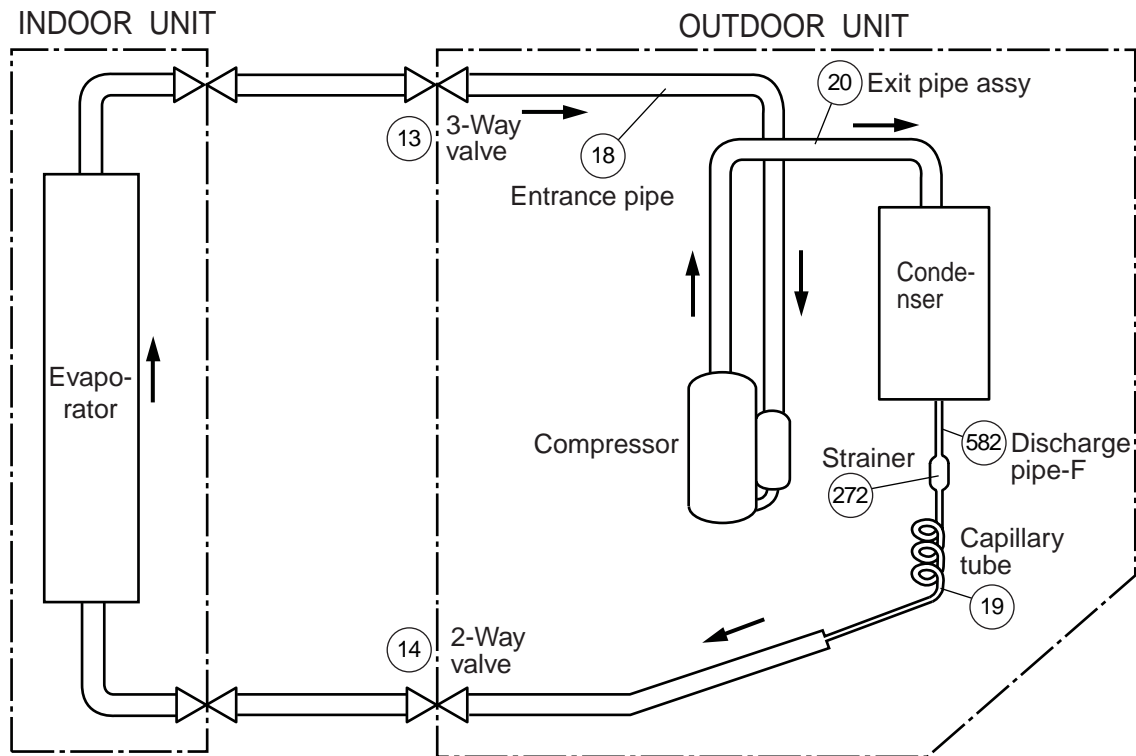

**Models : RSW-14HA / ROW-14RA**

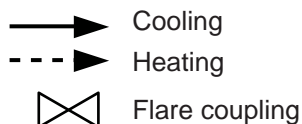
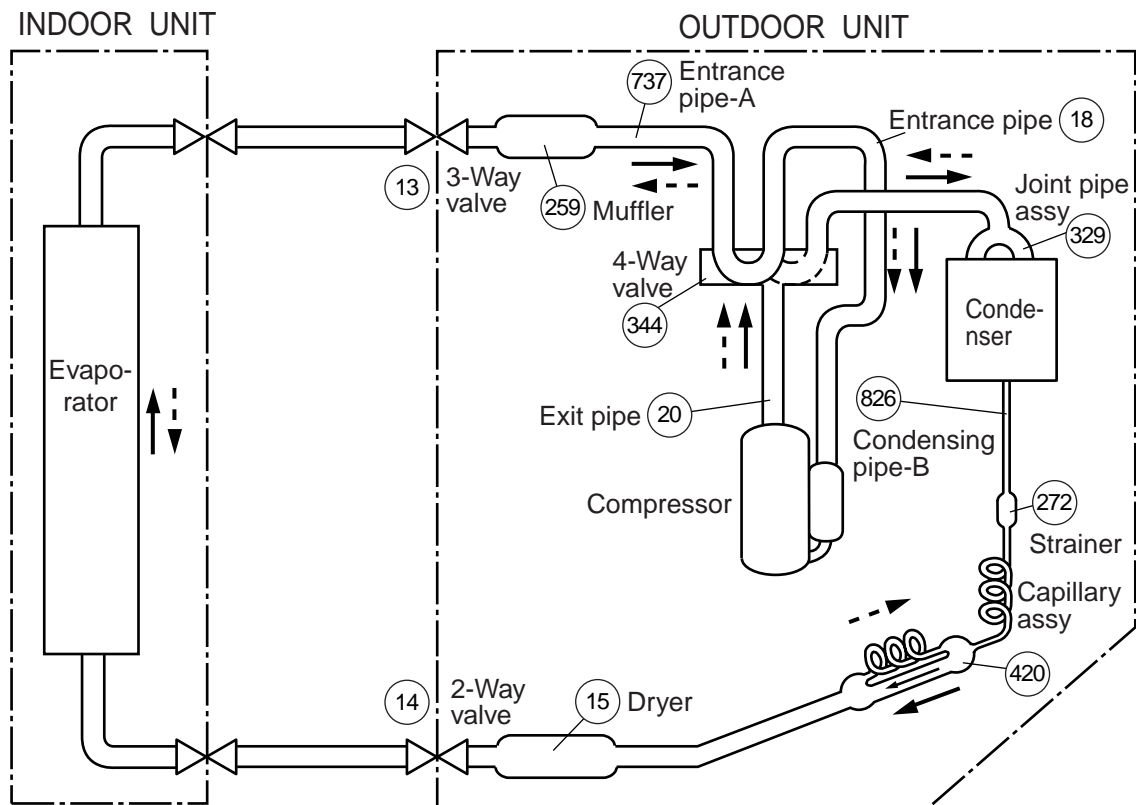

Circled figures show the Ref. No. in the parts list on page 20.

**Models : RSW-17CA / ROW-17CA**

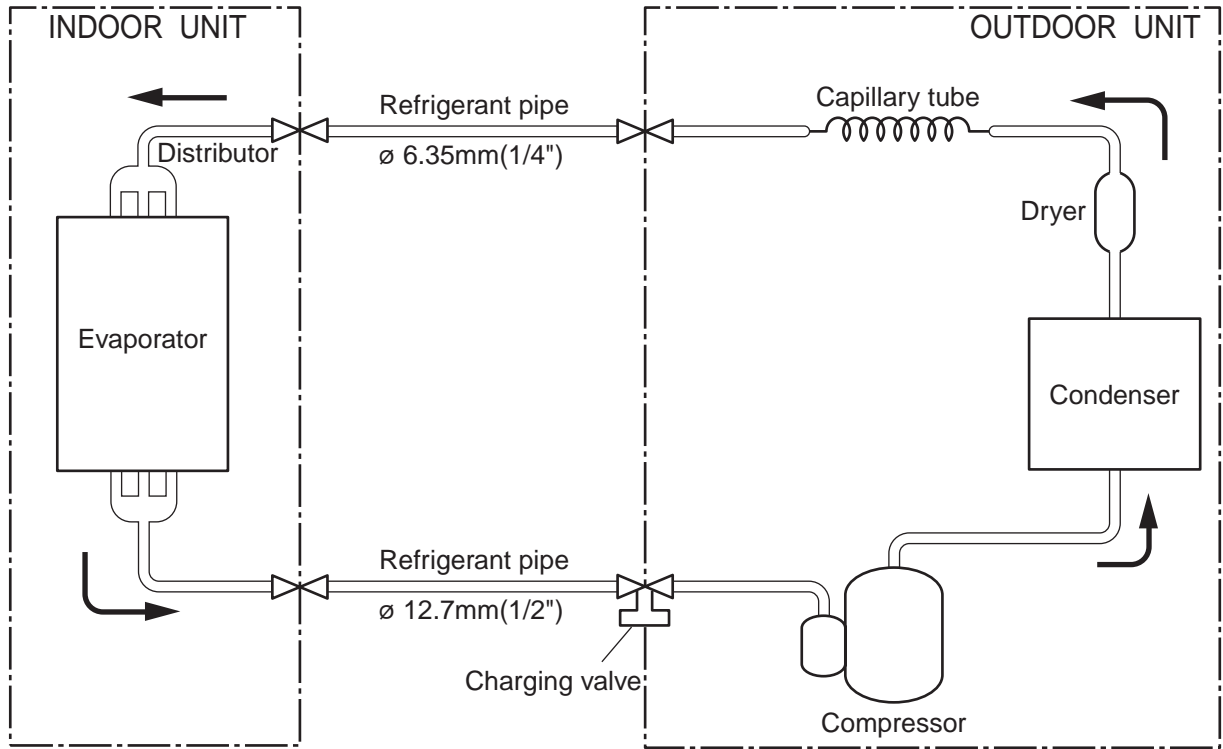

**Models : RSW-17HA / ROW-17RB**

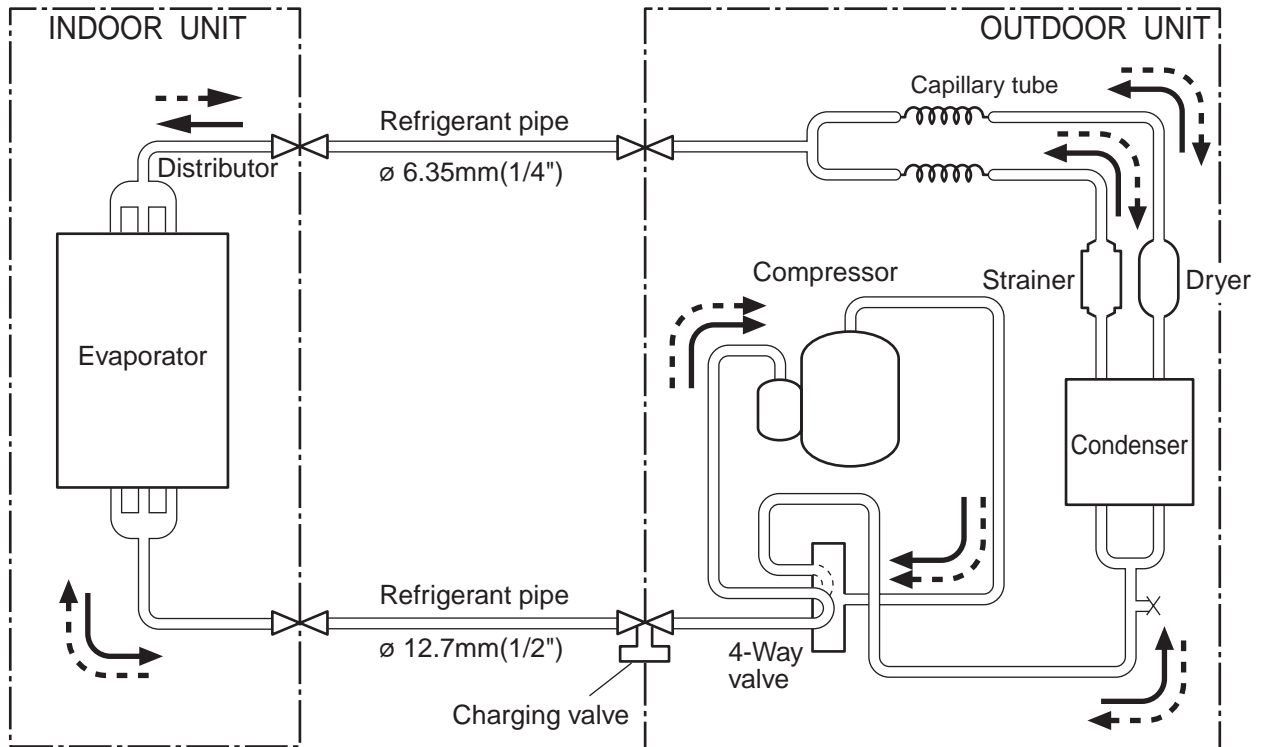

- Cooling
- - - - - Heating
- ⊗ : Flare coupling

# CIRCUIT DIAGRAM

Models : RSW-14CA / ROW-14AA

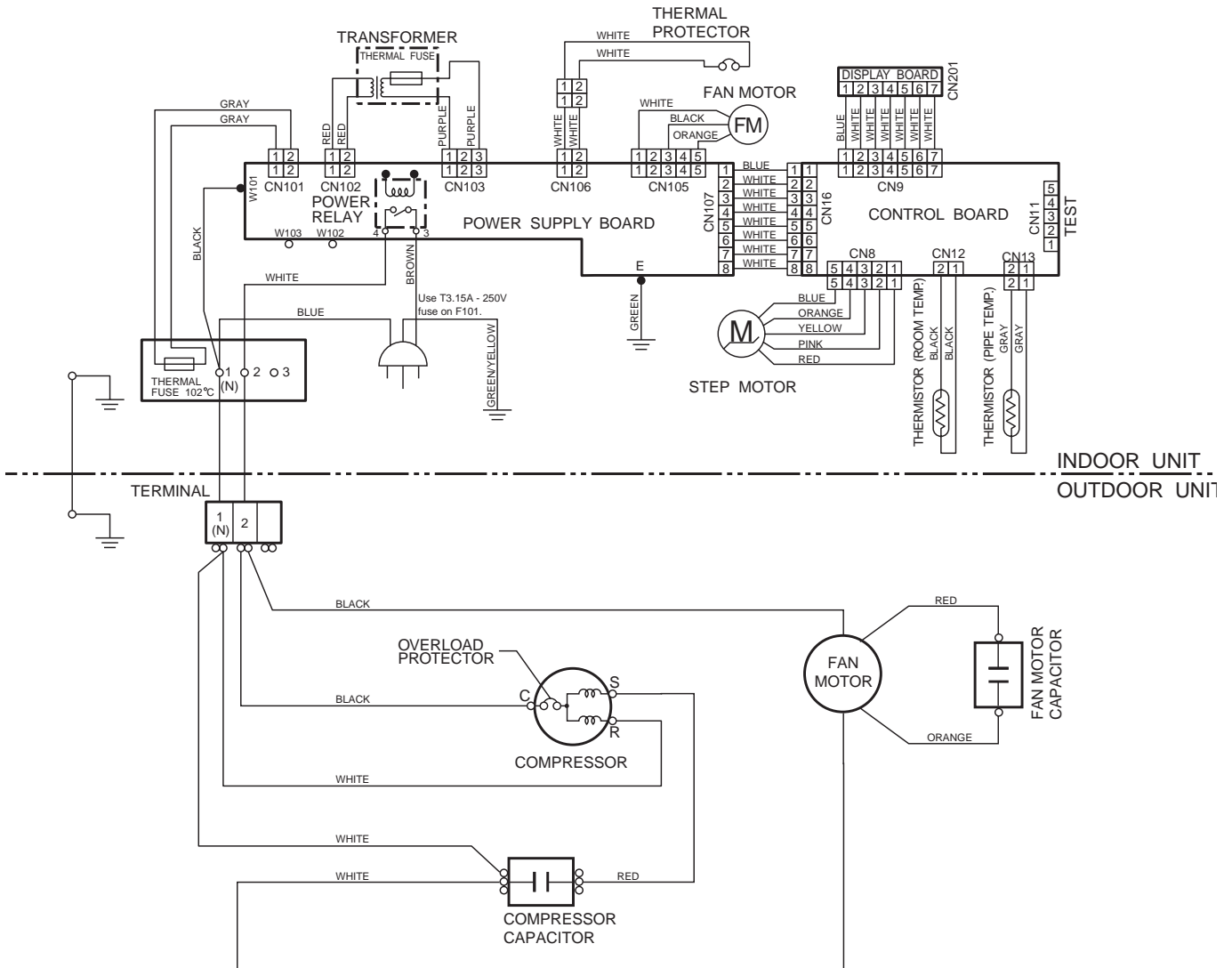

**Models : RSW-14HA / ROW-14RA**

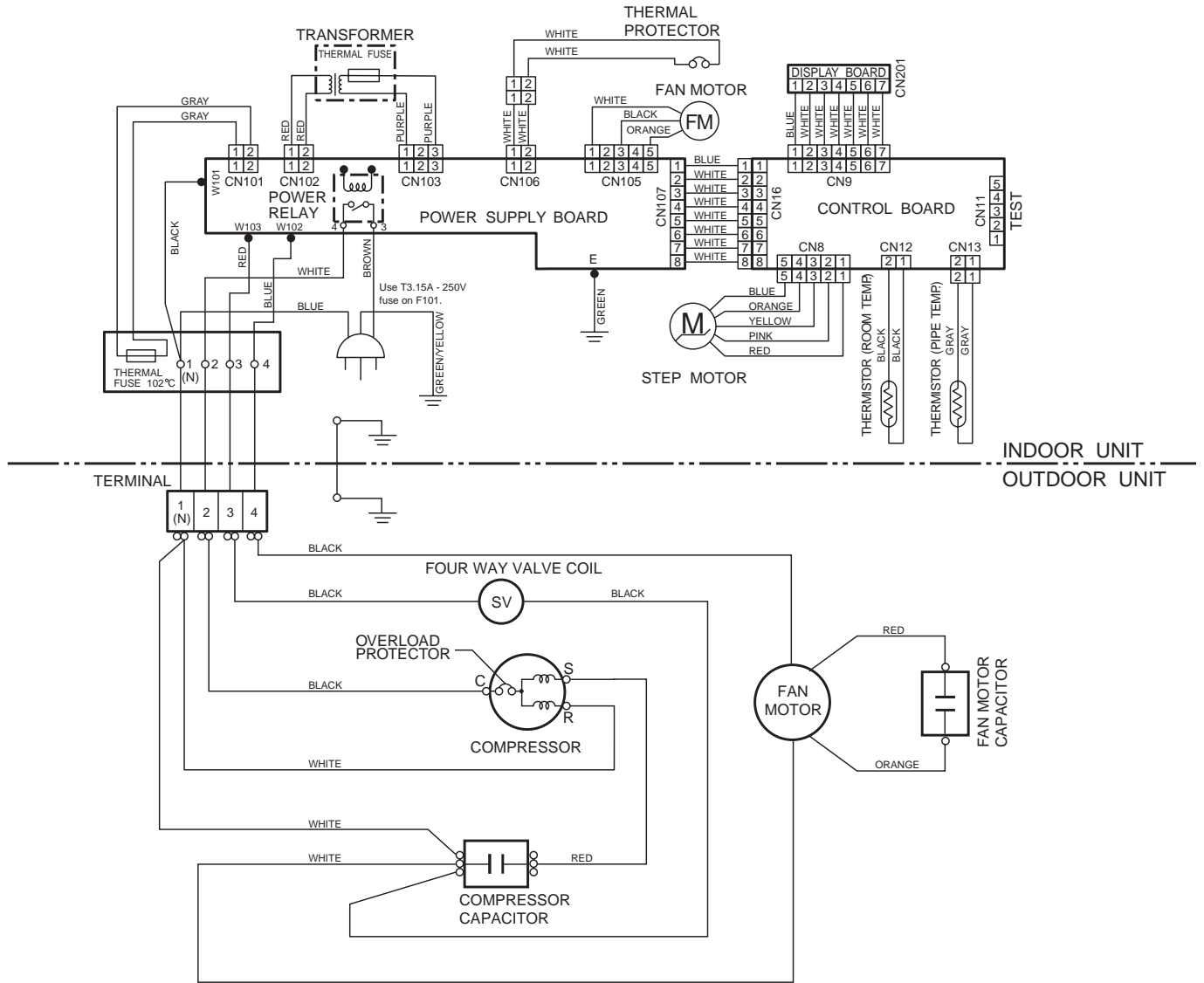

**Models : RSW-17CA / ROW-17CA**

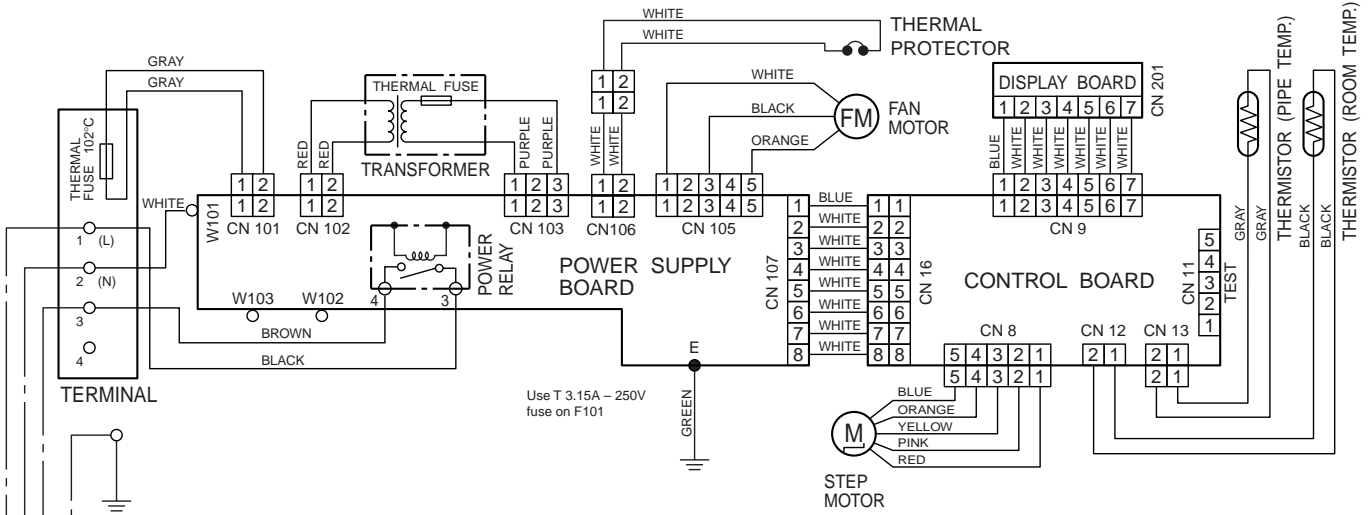

INDOOR UNIT  
OUTDOOR UNIT

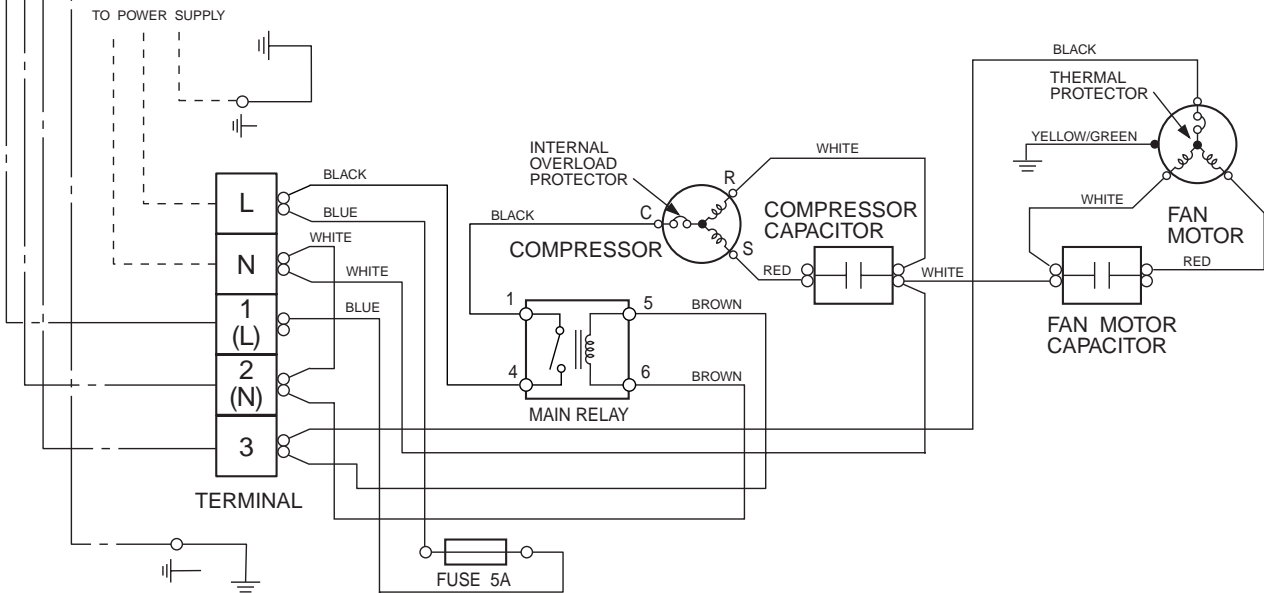



**Models : RSW-17HA / ROW-17RB**

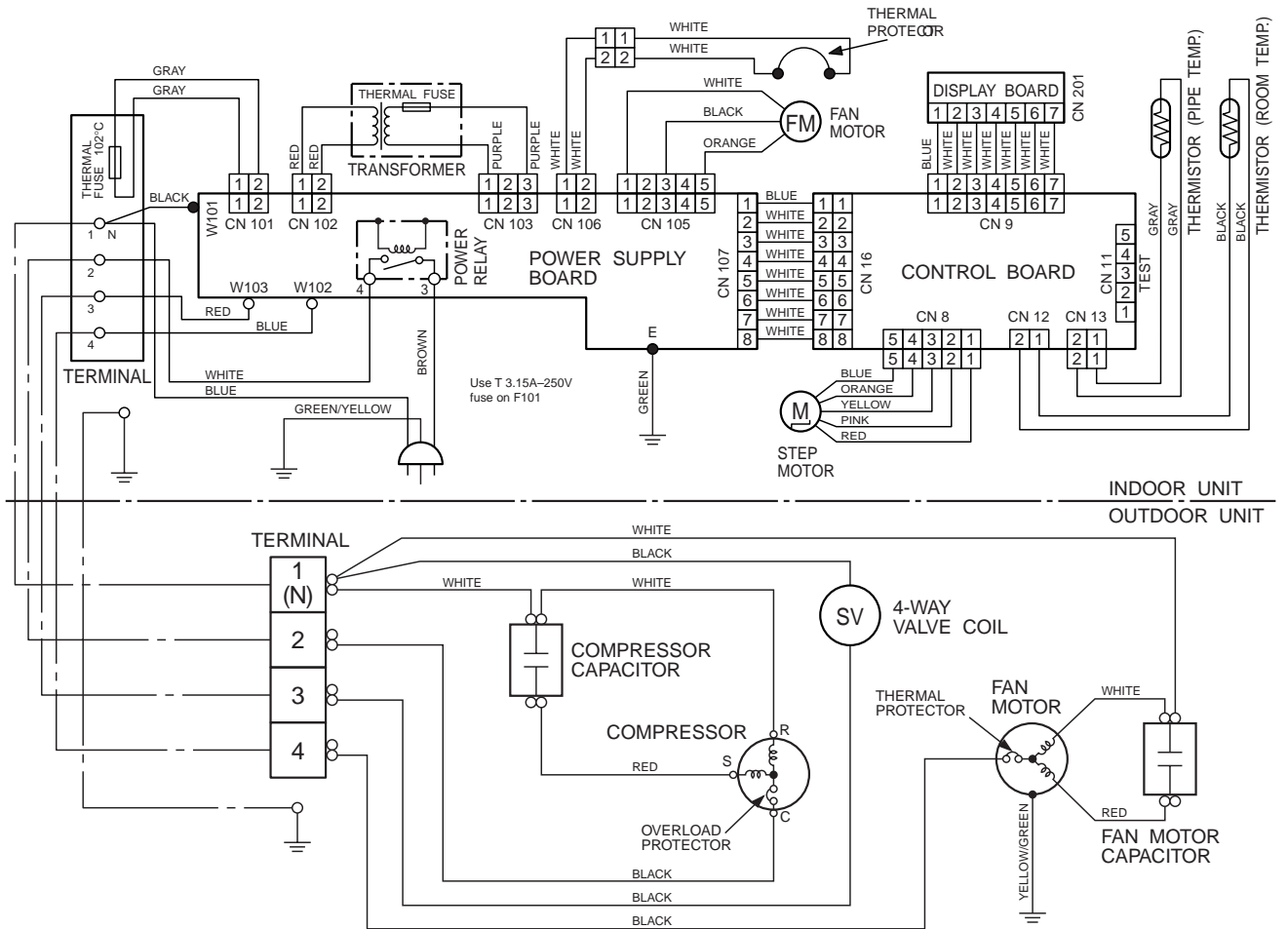

# P.C. BOARD LAYOUTS

## CONTROLLER PCB ASSEMBLY (MAIN PCB)

(Viewed from the solder side)

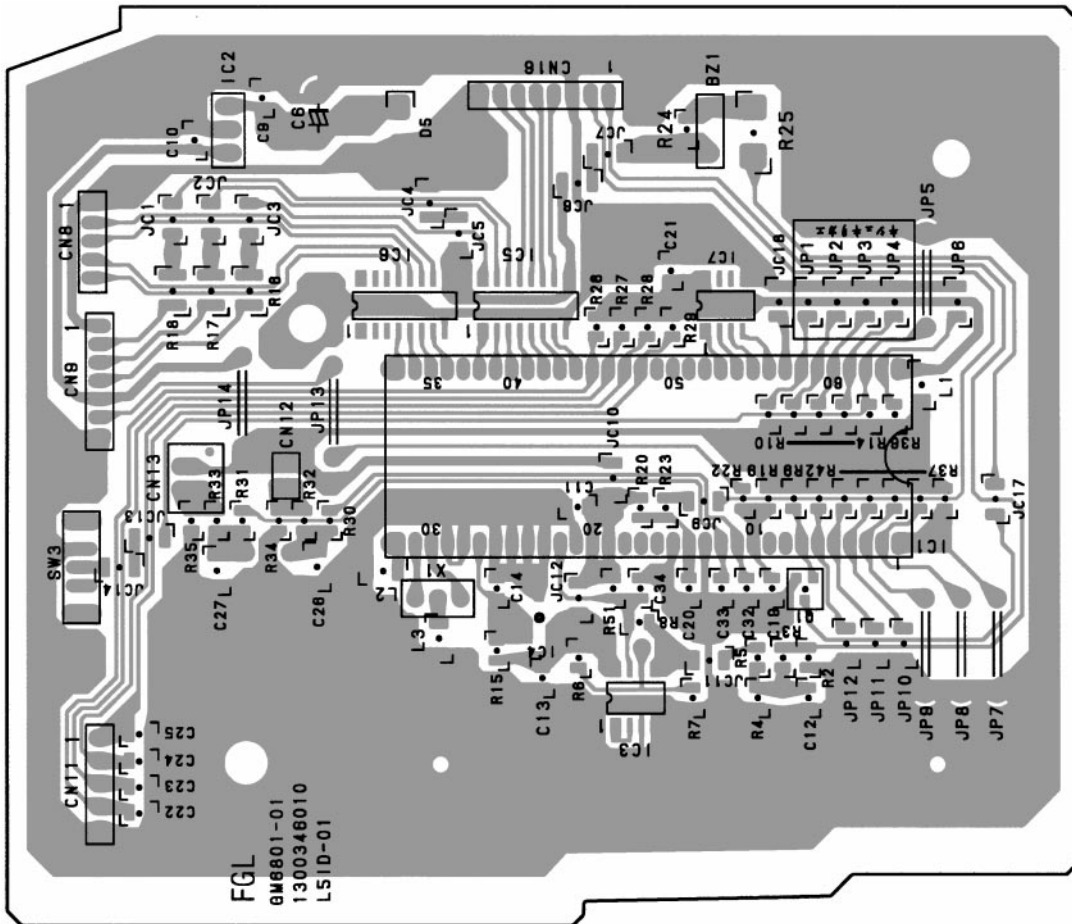

## POWER SUPPLY PCB ASSEMBLY

(Viewed from the solder side)

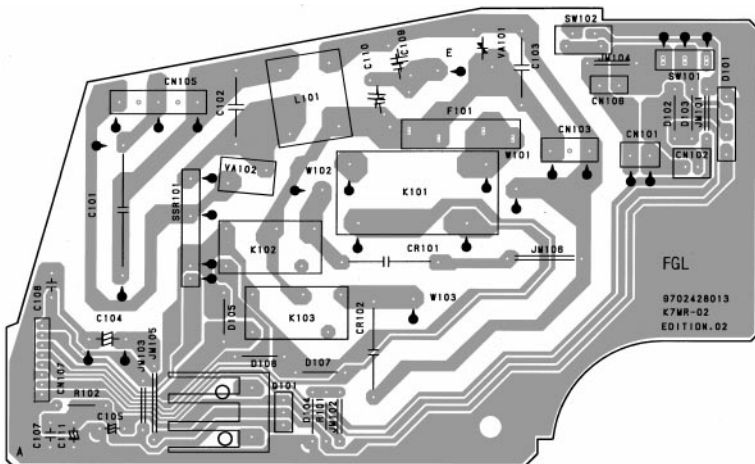

## INDICATOR PCB ASSEMBLY

(Viewed from the solder side)

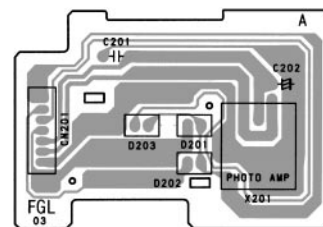

# INDOOR PRINTED CIRCUIT BOARD CIRCUIT DIAGRAM

Model : RSW-14CA

CONTROLLER PCB ASSEMBLY  
EZ-095GWSE-C (F)

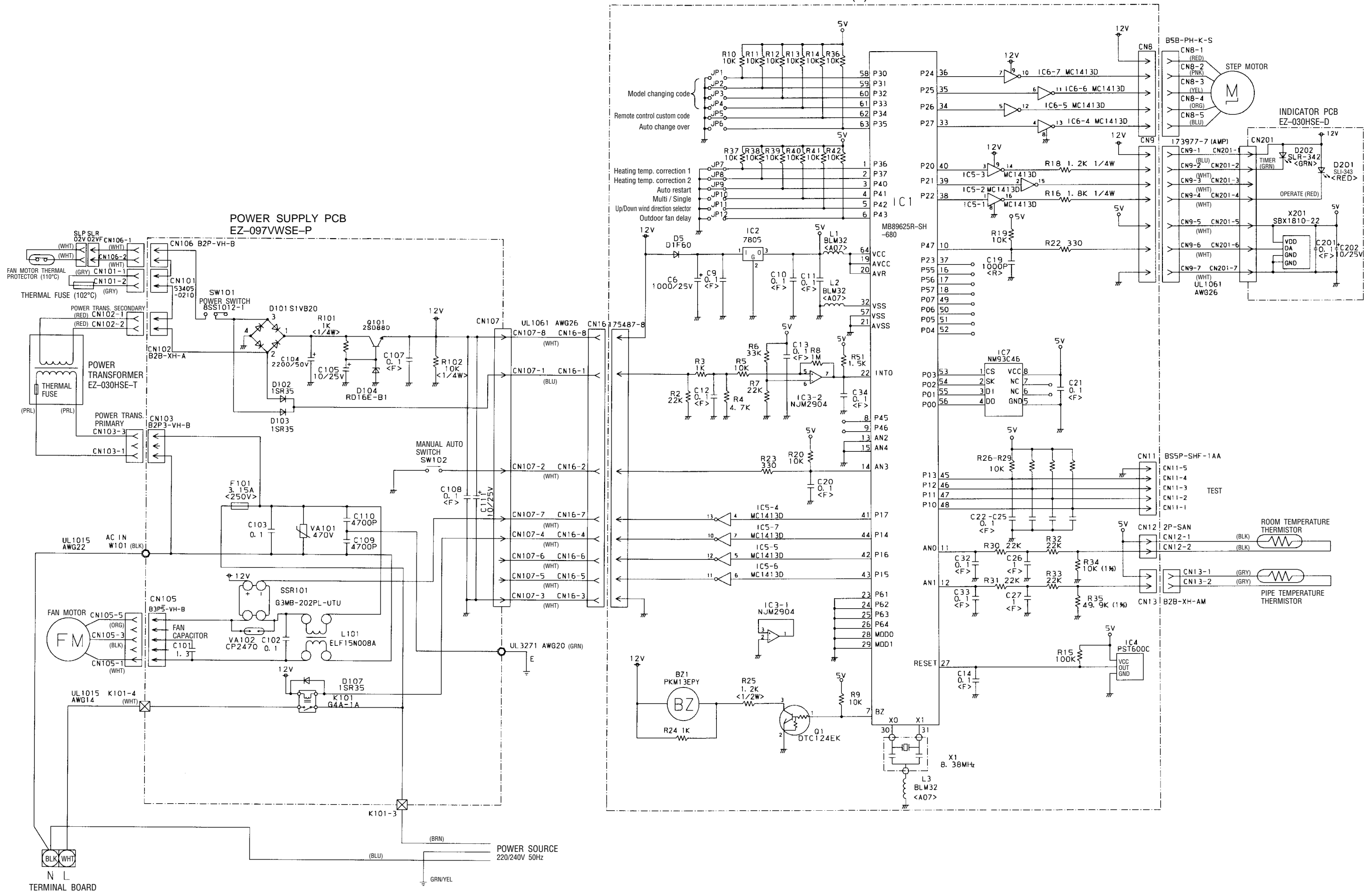

Models : RSW-14HA  
RSW-17HA

CONTROLLER PCB ASSEMBLY  
EZ-095RHSE-C (F)

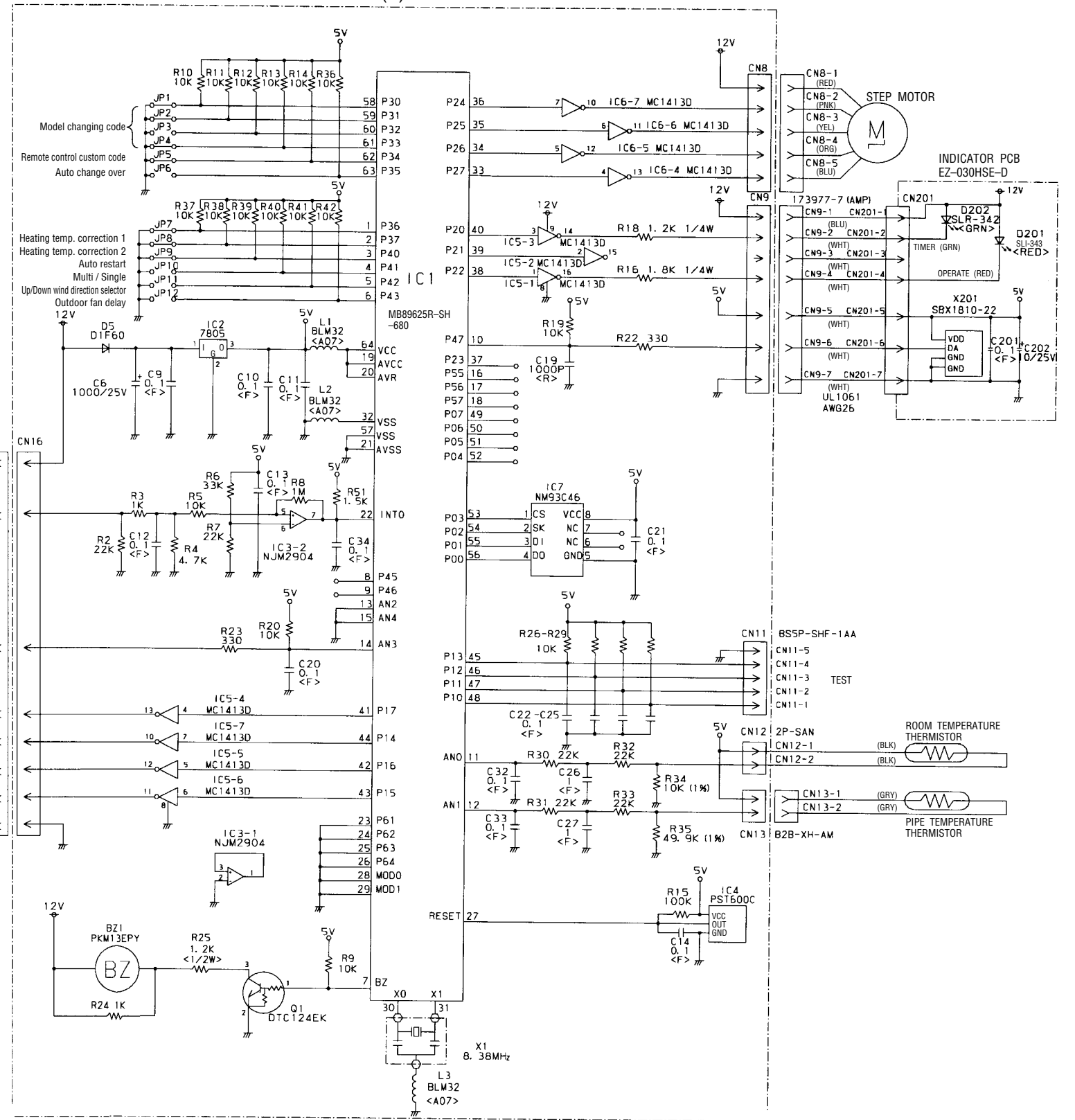
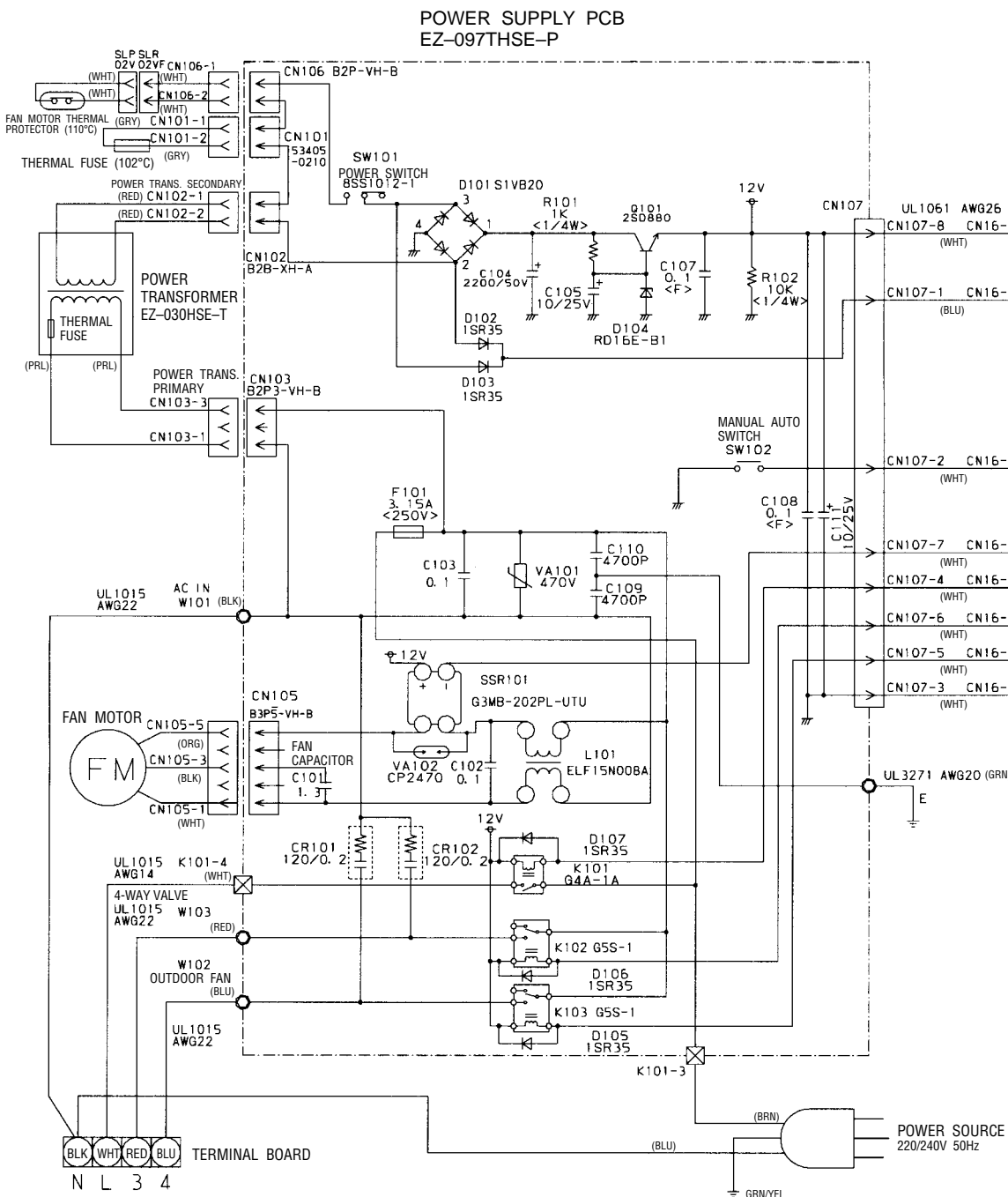

Model : RSW-17CA

# CONTROLLER PCB ASSEMBLY

## EZ-095GWSE-C (GM-6805)

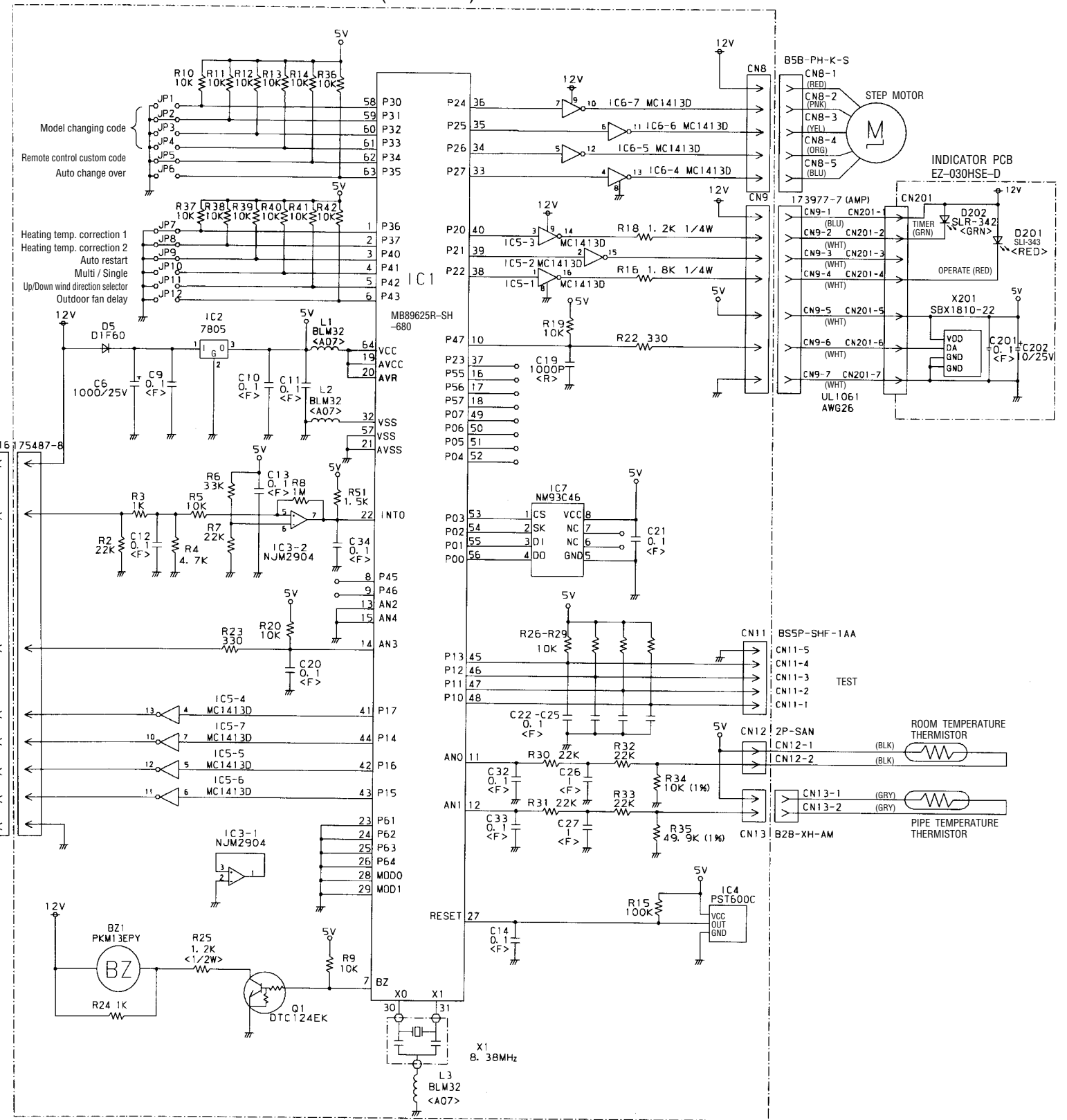
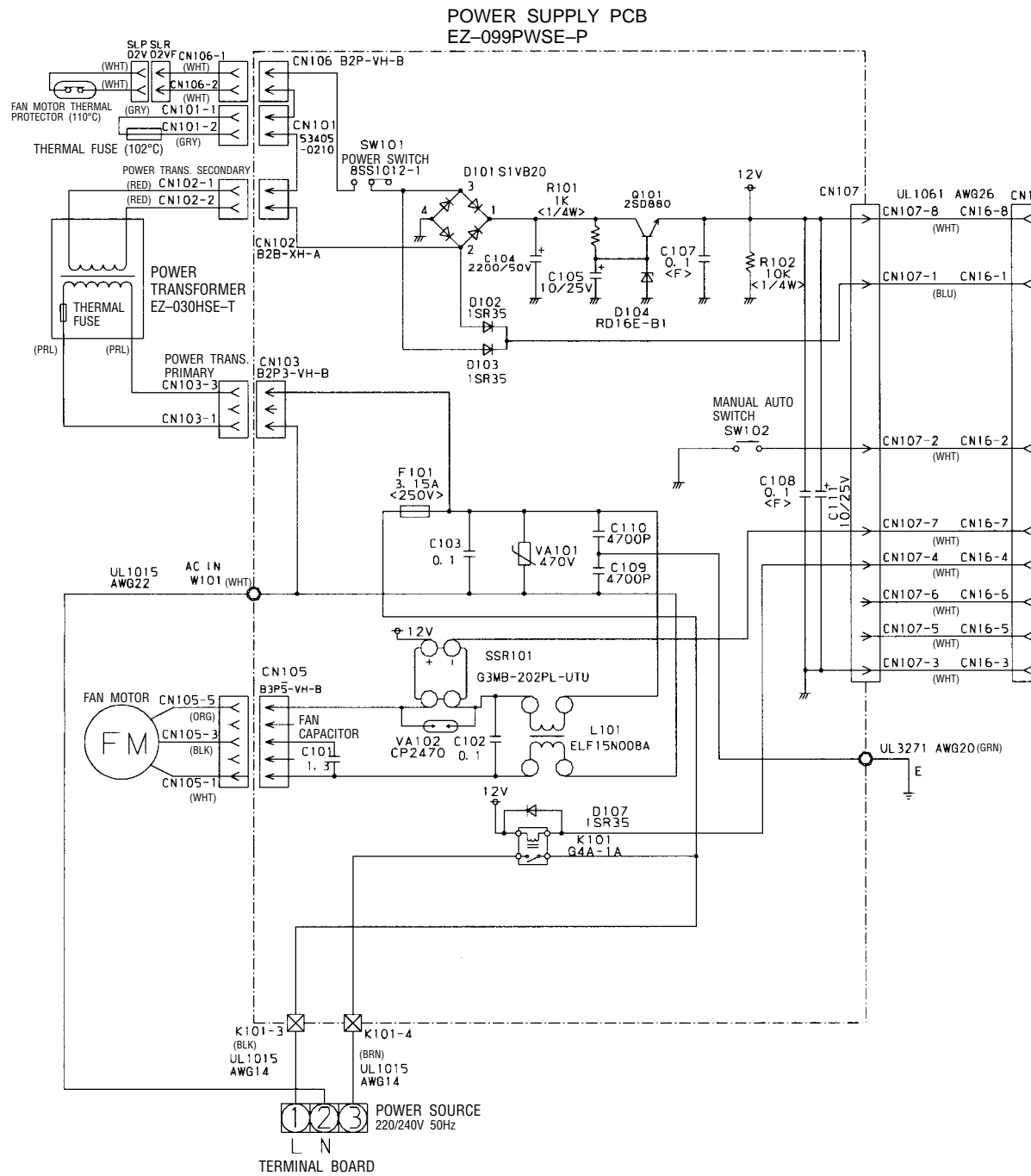

# DISASSEMBLY ILLUSTRATION

Models : RSW-14CA, RSW-14HA,  
RSW-17CA, RSW-17HA

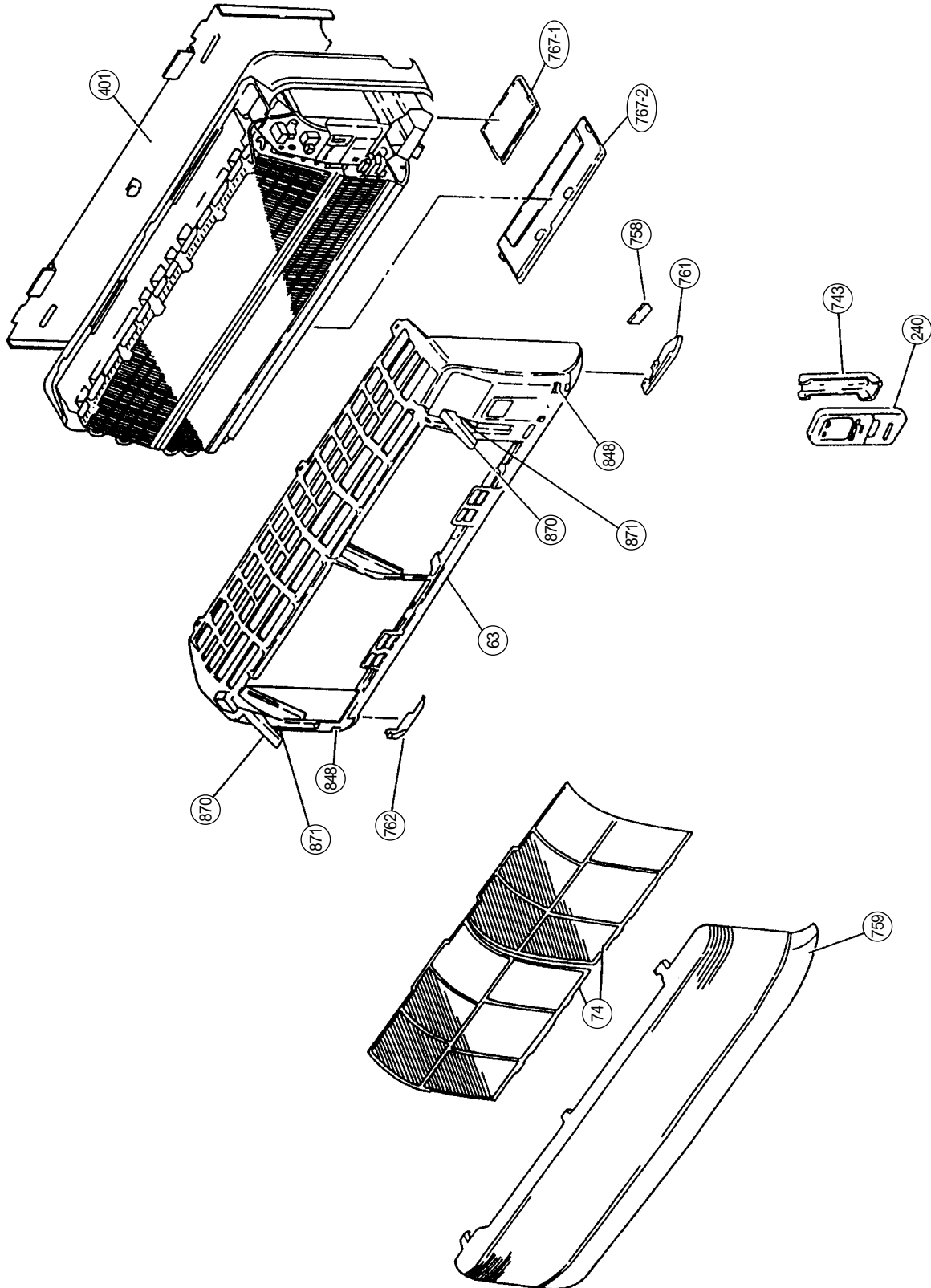

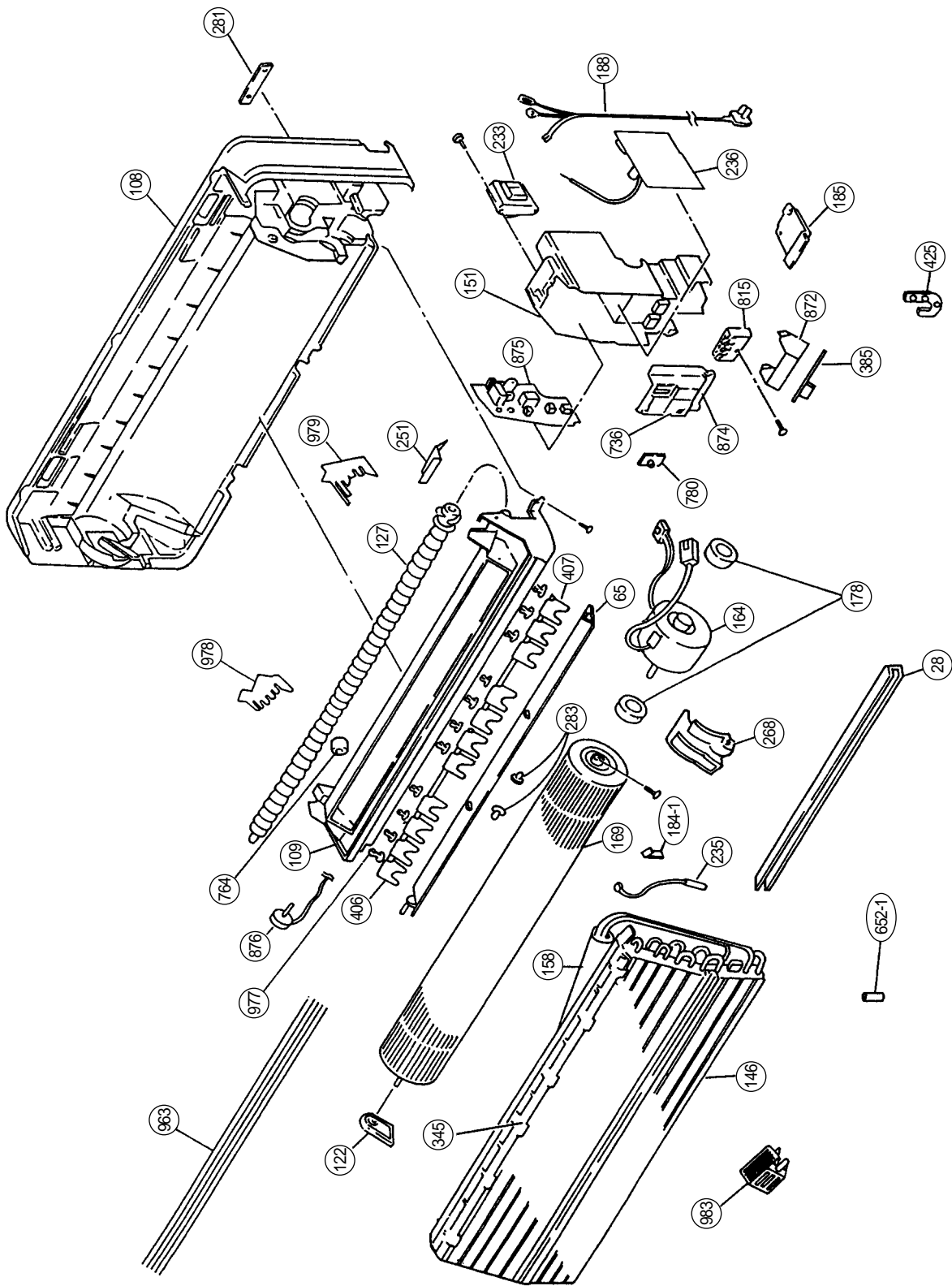

Models : ROW-14AA  
ROW-14RA

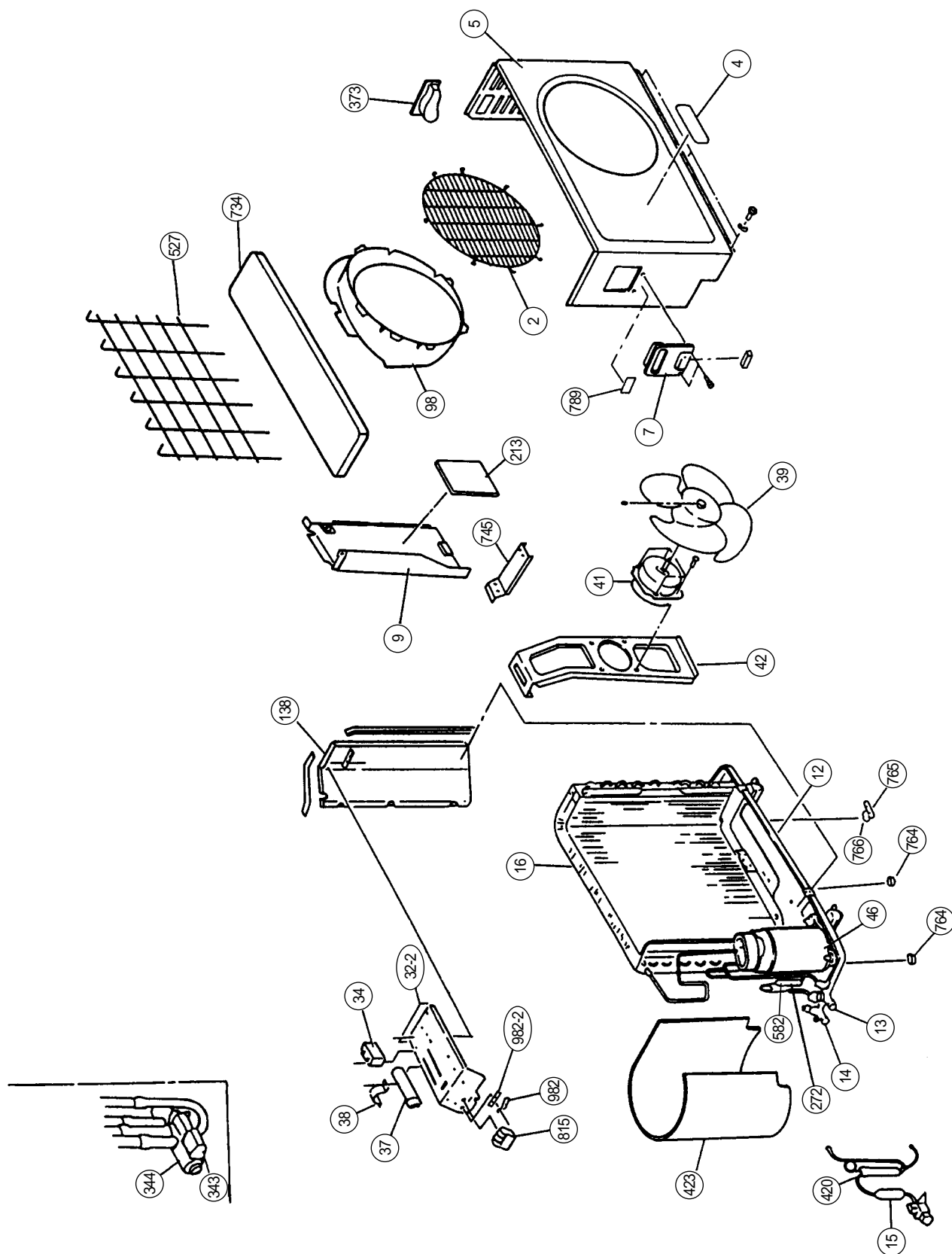



Models : ROW-17CA  
ROW-17RB

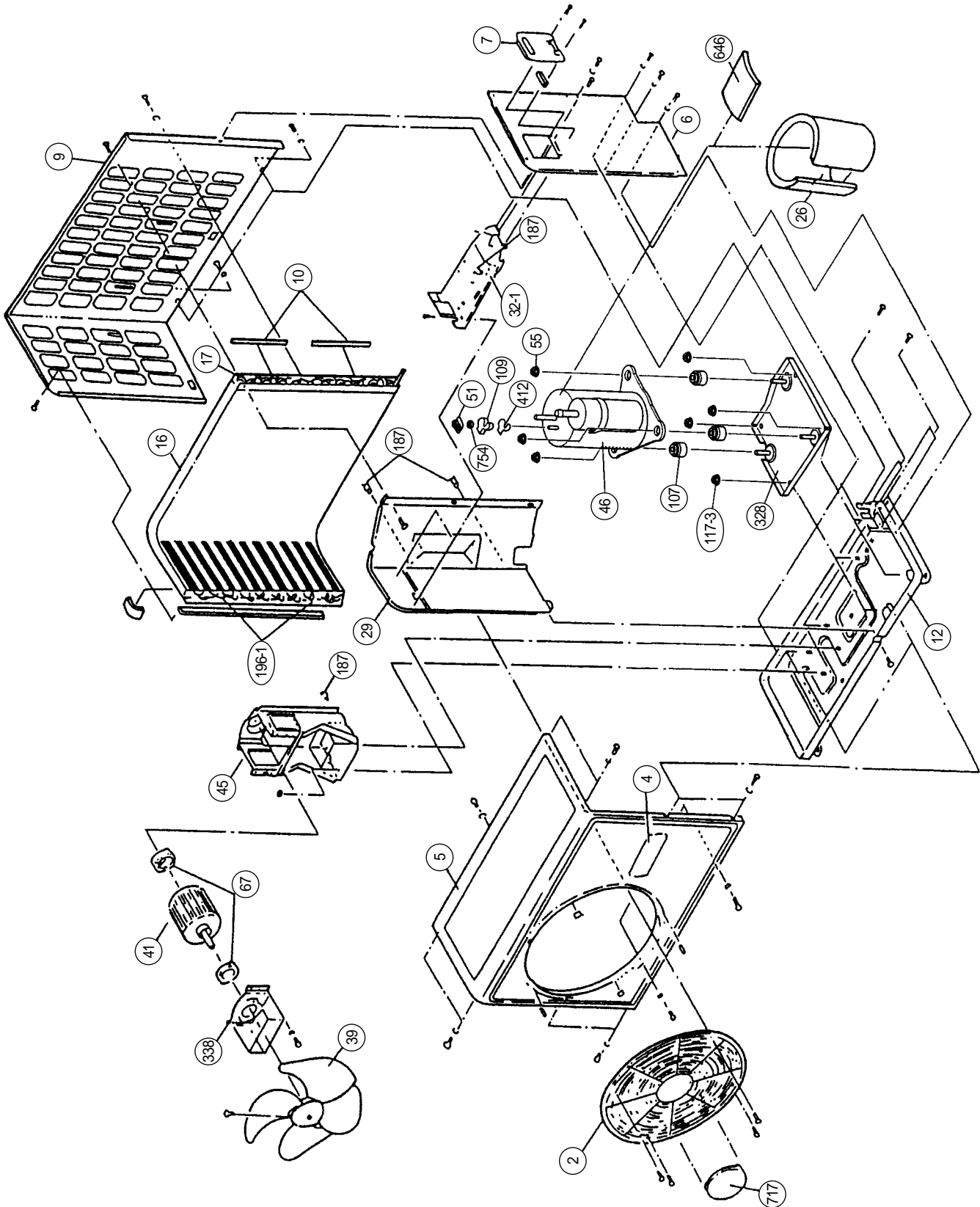

Models : ROW-14AA  
ROW-14RA

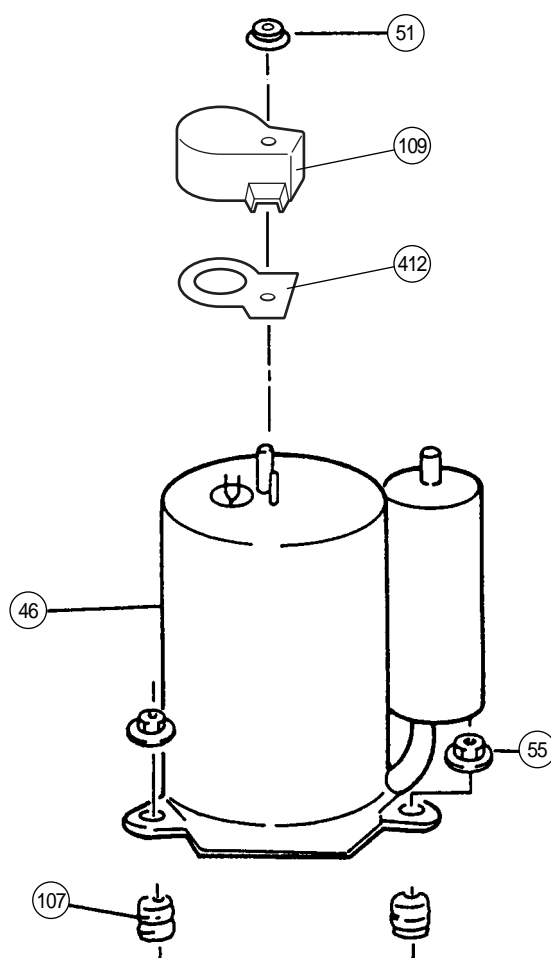

**Model : ROW-17CA**

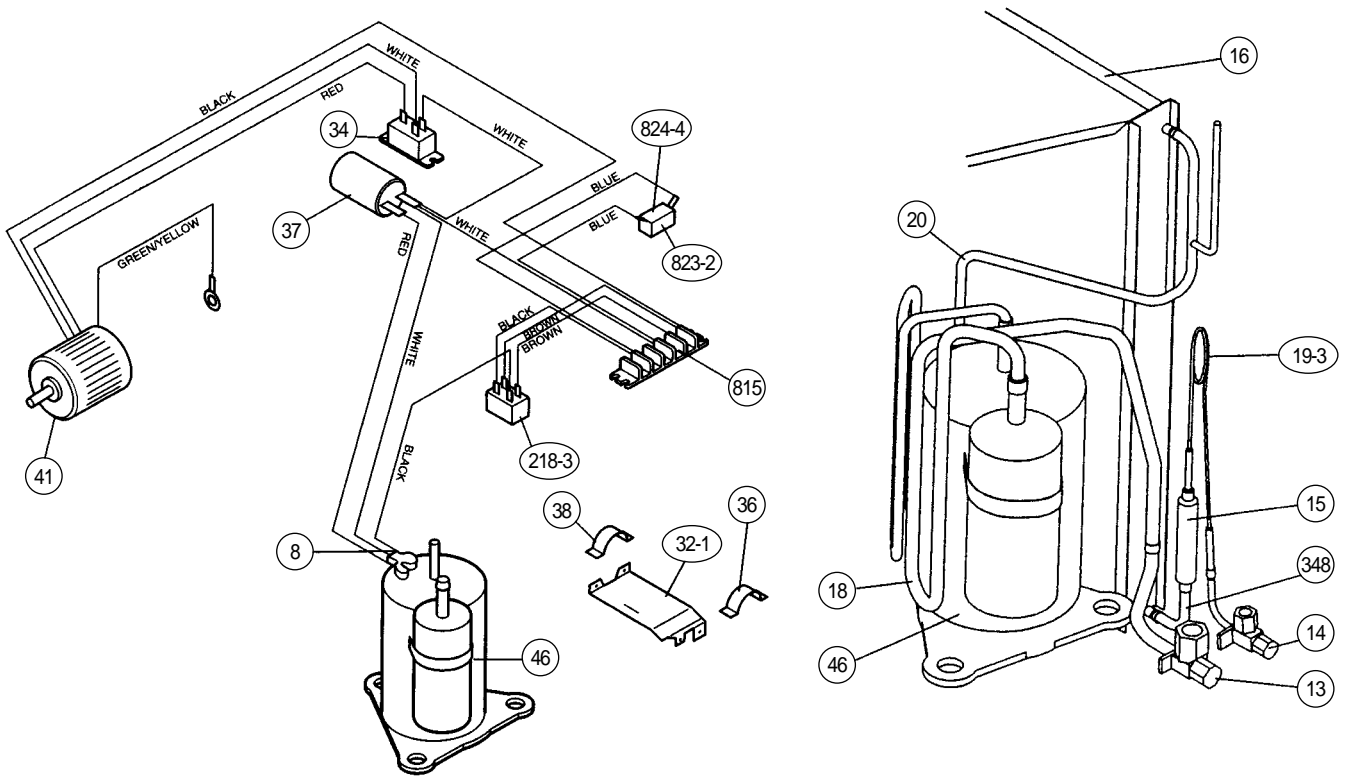

**Model : ROW-17RB**

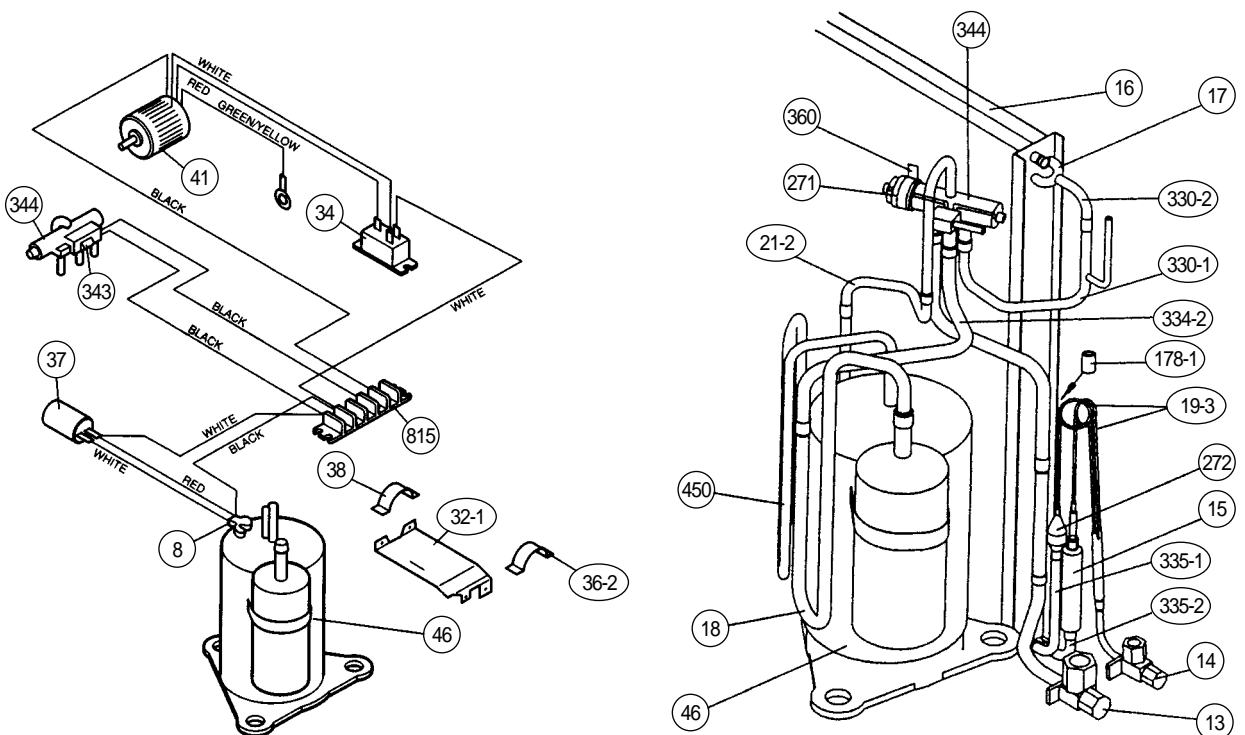

# PARTS LIST

When you order parts, please make a photocopy of this page and fill the number of the parts in the "Order" column.

## INDOOR UNIT

Ref. No.	Description	Part No.				Ord. Q'ty
		RSW-14CA	RSW-14HA	RSW-17CA	RSW-17HA	
28	Blower Cover	9304111016	9304111016	9304111016	9304111016	
63	Front Panel Assy "FUJI ELECTRIC"	9354229174	9354229174	9354229174	9354229174	
65	Flow Control Panel	9354646094	9354646094	9354646063	9354646063	
74	Filter	9304097013	9304097013	9304097013	9304097013	
108	Base	9304107033	9304107033	9304107033	9304107033	
109	Casing	9304108016	9304108016	9304108016	9304108016	
122	Shaft Holder-B Assy	9304470007	9304470007	9304470007	9304470007	
127	Drain Hose Assy	9368754013	9368754013	9368754013	9368754013	
146	Evaporator Assy	9304079002	9304079002	9304589006	9304589006	
151	Control Box	9304092001	9304092001	9304092001	9304092001	
158	Joint Pipe Assy	9304286011	9304286011	9304286011	9304286011	
164	Fan Motor Assy-IN	9354513044	9354513044	9354513044	9354513044	
169	Cross-Flow Fan Assy	9306327002	9306327002	9306327002	9306327002	
178	Motor Cushion-G	9304669005	9304669005	9304669005	9304669005	
184-1	Thermistor Spring-A	313728262708	313728262708	313728262708	313728262708	
185	Wire Clamp	9356959000	9356959000	9356959000	9356959000	
188	Power Cord Assy	9702595029	9702595029	—	9359917007	
233	Power Transformer	9701803026	9701803026	9701803026	9701803026	
235	Thermistor Assy-Pipe	9702325015	9702325015	9702325015	9702325015	
236	Controller PCB Assy	9704341013	9704341020	9704341013	9704341037	
240	Remote Control Unit	9356765076	9356765069	9356765076	9356765113	
251	Hose Clamp (Drain Hose)	9304077008	9304077008	9304077008	9304077008	
268	Motor Cover-B	9304231004	9304231004	9304231004	9304231004	
281	Clamp Metal (Pipe)	9304242000	9304242000	9304242000	9304242000	
283	Bushing-A	9303529010	9303529010	9303529010	9303529010	
345	Filter Guide	9304110019	9304110019	9304110019	9304110019	
385	Indicator PCB Assy	9701119219	9701119219	9701119219	9701119219	
401	Wall Hook Bracket	9304093008	9304093008	9304093008	9304093008	
406	Louver-L Assy	9354644014	9354644014	9354644014	9354644014	
407	Louver-R Assy	9354643017	9354643017	9354643017	9354643017	
425	Earth Terminal	9357852003	9357852003	9357852003	9357852003	
652-1	Thermistor Holder Pipe	313714262805	313714262805	313714262805	313714262805	
736	Operation Panel	9354230002	9354230002	9354230002	9354230002	
743	Remote Control Unit Holder Case	9305642014	9305642014	9305642014	9305642014	
758	Decoration Plate-A	9354223011	9354223011	9354223011	9354223011	
759	Intake Grille-A "FUJI"	9355595063	9355595063	9355595063	9355595063	
761	Side Cover-R	9303518076	9303518076	9303518076	9303518076	
762	Side Cover-L	9303520147	9303520147	9303520147	9303520147	
764	Drain Cap Assy	9304150008	9304150008	9304150008	9304150008	
767-1	Bottom Cover-A	9303536056	9303536056	9303536056	9303536056	
767-2	Bottom Cover-B	9303537053	9303537053	9303537053	9303537053	
780	Key Top (Slide Switch)	9303526002	9303526002	9303526002	9303526002	
815	Terminal-2P	9701955022	—	—	—	
815	Terminal-3P	—	—	9701955046	—	
815	Terminal-4P	—	9701955039	—	9701955039	
848	Catcher	9306545000	9306545000	9306545000	9306545000	
870	Arm	9303525005	9303525005	9303525005	9303525005	
871	Arm Spring	9304377009	9304377009	9304377009	9304377009	
872	Indicator Case	9303631003	9303631003	9303631003	9303631003	
874	Control Box Cover	9304094005	9304094005	9304094005	9304094005	
875	Power Supply PCB Assy	9702451073	9702451066	9702451080	9702451066	
876	Step Motor	9304535003	9304535003	9304535003	9304535003	
963	Fan Guard	9356881011	9356881011	9356881011	9356881011	
977	Louver Clip, Plastic	9356880014	9356880014	9356880014	9356880014	
978	Wire Bracket-L	9356878011	9356878011	9356878011	9356878011	
979	Wire Bracket-R	9356877014	9356877014	9356877014	9356877014	
983	Thermistor Protect Cover	9356882001	9356882001	9356882001	9356882001	

ROW-14AA  
ROW-14RA  
ROW-17CA  
ROW-17RB

When you order parts, please make a photocopy of this page and fill the number of the parts in the "Order" column.

**OUTDOOR UNIT**

Ref. No.	Description	Part No.				Ord. Q'ty
		ROW-14AA	ROW-14RA	ROW-17CA	ROW-17RB	
2	Fan Cover	9304109006	9304109006	9350214020	9350214020	
4	Emblem-Rear "FUJI ELECTRIC"	9361328006	9361328006	9361328006	9361328006	
5	Cabinet, Painted	9302936017	9302936017	—	—	
5	Cabinet-A, Painted	—	—	9303876015	9303876015	
6	Cabinet-C, Painted	—	—	9353549013	9353549013	
7	Connector Cover (Cabinet)	9357970004	9357970004	9358011010	9358011010	
8	Wire Assy (Shield Tube)-D	—	—	9359904076	9359904076	
9	Cabinet Rear Panel	9303744017	9303744017	—	—	
9	Cabinet-B, Painted	—	—	9303874011	9303874011	
10	Noise Insulation-E	—	—	313791106305	313791106305	
12	Base Assy, Painted	9354493070	9354493070	9353452054	9353452054	
13	3-Way Valve Assy	9364616001	9364616001	9364524009	9364524009	
14	2-Way Valve	9364615004	9364615004	9358023013	9358023013	
15	Dryer	—	313523082505	9353789006	9353789006	
16	Condenser Assy	9365671009	9365670002	9353455055	9353455048	
17	"U" Pipe-Y	—	—	—	313728127102	
18	Entrance Pipe	9364832005	9364827001	—	—	
18	Suction Pipe-A	—	—	9368184001	9365242001	
19	Capillary Tube	9364835006	—	—	—	
19-3	Capillary Tube (Cool)	—	—	9363436006	9363481006	
20	Exit Pipe	—	9364826004	—	—	
20	Exit Pipe Assy	9364832005	—	—	—	
20	Discharge Pipe Assy	9368182007	9364826004	9368182007	—	
21-2	Discharge Pipe-B	—	—	—	9365241004	
26	Compressor Cover-A	—	—	9363620007	9363620007	
29	Separate Wall	—	—	313986033213	313986033213	
32-1	Control Box Metal-A	—	—	9365672013	9365672013	
32-2	Control Box Metal-A	9355843003	9355843003	—	—	
34	Capacitor (Fan Motor)	9700468080	9700468080	9357965017	9357965017	
36	Cord Holder Metal	—	—	9356934007	—	
36-2	Cord Holder Metal	—	—	—	9356362008	
37	Running Capacitor	9351208066	9351208066	9704436023	9704436023	
38	Capacitor Clamp Metal	313468061808	313468061808	9351770013	9351770013	
39	Propeller Fan Assy	9351589011	9351589011	9300855013	9300855013	
41	Motor Induction-Outer	9601113010	9601113010	—	—	
41	Fan Motor Assy-OUT	—	—	9600738023	9600738023	
42	Motor Fixing Table	313166243804	313166243804	—	—	
45	Motor Fixing Table Assy	—	—	313029311100	313029311100	
46	Compressor Assy	9364723006	9364723006	9368175009	9363446005	
51	Special Nut M5 (For Comp.)	9359430018	9359430018	9300301015	9300301015	
55	Special Nut M8 (For Comp.)	9355091008	9355091008	313252257701	313252257701	
67	Rubber (Vibration-proof)	—	—	313659068604	313659068604	
98	Fan Ring	313166296109	313166296109	—	—	
107	Rubber Seat-A (For Comp.)	9359425014	9359425014	9351049010	9351049010	
109	Terminal Cover (For Comp.)	9364724003	9364724003	9351048013	9351048013	
117-3	Hex. Nut Washer Spring	—	—	301721180114	301721180114	
138	Separate Wall	9303729014	9303729014	—	—	
178-1	Capillary Holder Rubber	—	—	—	313414274807	
187	Clamp No. 1219	—	—	313361271706	313361271706	
196-1	Clamp SKB-3M	—	—	—	312300787605	
213	Noise Insulation-B	313584258005	313584258005	—	—	
218-3	Power Relay	—	—	9704171016	—	
259	Muffler	—	313505083900	—	—	
271	4-Way Valve Rubber	—	—	—	313728251908	
272	Strainer	9357309002	9301340006	—	9350379026	
328	Compressor Plate-B	—	—	9363049015	9363049015	
329	Coupling Pipe Assy	—	9352375002	—	—	
330-1	Inlet Pipe (Cond.) Assy	—	—	—	9363476002	
330-2	Inlet Pipe (Cond.)-B	—	—	—	9363495003	
334-2	Suction Pipe-B	—	—	—	9365243008	

When you order parts, please make a photocopy of this page and fill the number of the parts in the "Order" column.

**OUTDOOR UNIT (Continued)**

Ref. No.	Description	Part No.				Ord. Q'ty
		ROW-14AA	ROW-14RA	ROW-17CA	ROW-17RB	
335-1	Outlet Pipe-A	—	—	—	9363489002	
335-2	Outlet Pipe-B	—	—	—	9363488005	
338	Motor Fixture Metal	—	—	313029297108	313029297108	
343	Solenoid Coil	—	9704061034	—	9704061010	
344	4-Way Valve	—	9307556012	—	9307556012	
348	Outlet Pipe	—	—	9363433005	—	
360	4-Way Valve Band	—	—	—	313986251802	
373	Grip	313166178700	313166178700	—	—	
412	Terminal Gasket (Comp.)	9364725000	9364725000	9351051013	9351051013	
420	Capillary Assy	—	9364828008	—	—	
423	Noise Insulation-F	9350944019	9350944019	—	—	
450	Discharge Pipe-A	—	—	—	9365240007	
527	Protection Net	9355444002	9355444002	—	—	
582	Discharge Pipe-F	9301425017	—	—	—	
646	Compressor Cover-B	—	—	9363021004	9363021004	
717	Center Plate	—	—	9351253011	9351253011	
734	Cabinet Top Plate	9302937014	9302937014	—	—	
737	Entrance Pipe-A	—	9352384004	—	—	
744	Clamp (Condenser)	313166374106	313166374106	—	—	
745	Motor Support	313166036308	313166036308	—	—	
754	Terminal Gasket Washer	—	—	9351053017	9351053017	
764	Drain Cap	—	313166024302	—	—	
765	Drain Pipe L-type	—	9301102000	—	—	
766	Drain Pipe Packing	—	9301143003	—	—	
815	Terminal-3P	9355901024	—	—	—	
815	Terminal-4P	—	9358660041	—	—	
815	Terminal-5P	—	—	9356497021	9356497021	
823-2	Fuse Holder	—	—	0500063024	—	
824-4	Fuse	—	—	0600222529	—	
826	Condensing Pipe-B	—	9353015006	—	—	
982	Cord Clamp	9356857009	9356857009	—	—	
982-2	Cord Clamp-B	9356858006	9356858006	—	—	
987	Insulation Sheet	9358372005	9358372005	—	—	

When you order parts, please make a photocopy of this page and fill the number of the parts in the "Order" column.

**CONTROLLER PCB ASSEMBLY (Ref. No. 236)**

Ref. No.	Description	Part No.	Ord. Q'ty	Ref. No.	Description	Part No.	Ord. Q'ty
IC1	IC MB89625R-SH-680	1300413033		R35	Res. 1/10W 49.9kΩ±1%	0200279824	
IC2	IC NJM7805FA	0100462081		R51	Res. 1/10W 1.5kΩ±5%	0200212784	
IC3	IC NJM2904M	0100534054		JC1,3~7,9~12, 17,18	Res. 0Ω	0200230016	
IC4	IC PST600CMT	0101461120		JP(1), 2, (4)	Res. 0Ω	0200230016	
IC5,6	IC MC1413D	0101736013		C6	Cap. Elec. 25V 1000μF	0300631256	
IC7	IC BR93LC46RF-E2	0100295016		C9~14,20~25, 32~34	Cap. Ceramic 25V 0.1μF	0300266748	
Q1	Xstr DTC124EKA	0000936033		C19	Cap. Ceramic 50V 1000pF	0300308509	
D5	Diode D1F60	0000208024		C26,27	Cap. Ceramic 16V 1μF	0300316153	
R2,7,30~33	Res. 1/10W 22kΩ±5%	0200213095		X1	Ceramic Resonator CST8.38MTW-TF01	0400061021	
R3,24	Res. 1/10W 1kΩ±5%	0200212746		BZ1	Buzzer PKM13EPY-4000-TF01	9701298013	
R4	Res. 1/10W 4.7kΩ±5%	0200212906		L1~3	EMI Filter BLM 31 A601S	0400119029	
R5,9~14,19,20, 26~29,36~42	Res. 1/10W 10kΩ±5%	0200213019		CN8	Plug, PCB B5B-PH-K-S	0500200061	
R6	Res. 1/10W 33kΩ±5%	0200213132		CN9	Plug, PCB 175487-7	0500891016	
R8	Res. 1/10W 1MΩ±5%	0200213491		CN11	Plug, PCB BS5P-SHF-1AA	0500898015	
R15	Res. 1/10W 100kΩ±5%	0200213255		CN12	Plug, PCB 150-103-86100	9700801023	
R16	Res. 1/4W 1.8kΩ±5%	0200708805		CN13	Plug, PCB B2B-XH-A	0500005055	
R18	Res. 1/4W 1.2kΩ±5%	0200708768		CN16	Plug, PCB 175487-8	0500891023	
R22,23	Res. 1/10W 330Ω±5%	0200212623		JP5,7~9,13,14	Wire 0.6 dia. 10 mm	9700025016	
R25	Res. 1/2W 1.2kΩ±5%	0200731766					
R34	Res. 1/10W 10kΩ±1%	0200279497					

**POWER SUPPLY PCB ASSEMBLY (Ref. No. 875)**

( ) : Reverse cycle model









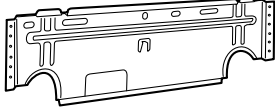

Ref. No.	Description	Part No.	Ord. Q'ty	Ref. No.	Description	Part No.	Ord. Q'ty
Q101	Xstr 2SD880	0000001014		SW102	Push KSM0632B	9703476013	
D101	Diode S1VB20	0000292054		F101	Fuse BET 3.15A-250V	0600222512	
D102,103	Diode 1SR139-400	0000353137		CN101	Plug, PCB 53405-0210	0500940011	
D104	Diode RD16EB1	0000296014		CN102	Plug, PCB B2B-XH-A	0500005055	
R101	Res. Carbon 1/4W 1kΩ±5%	0201038758		CN103	Plug, PCB B2P3-VH-B	0500011728	
R102	Res. Carbon 1/4W 10kΩ±5%	0201005019		CN105	Plug, PCB B3P5-VH-B	0500011735	
C101	Cap. Plastic 400V 1.3μF	0300939048		CN107	Plug, PCB B2P-VH-B	0500011124	
C102,103	Cap. Plastic 0.1μF	0300304075		CN106	Wire w/Connector L=180mm	9701052011	
C104	Cap. Elec. 50V 2000μF	0301190981		JM101~103	Wire 0.6mm dia. L=10mm	9700025016	
C105,111	Cap. Elec. 25V 10μF	0300099339		JM105, (106)	Wire 0.6mm dia. L=15mm	9700672012	
C107,108	Cap. Ceramic 0.1μF	0300988251		HT	Heat Sink PUG-16	9704578013	
C109,110	Cap. Ceramic 4700pF	0300209110		W101	Wire w/Terminal L=190mm BLK	9701169191	
VA101	Varistor TNR10V471K	0000361224		E	Wire w/Terminal L=250mm GRN	9701150014	
VA102	Varistor CP2470-F	9701835010			Fuse Holder SN-5057	9700116011	
SSR101	Relay G3MB-202PL-UTU	9701375011		(CR101,102)	CR Absorber RPEL-121204-C	9701125012	
K101	Relay G4A-1A-E-PS	9703454011		(K102,103)	Relay G5S-1	9701925018	
L101	EMI Filter ELF15N008A	0400165071		(W102)	Wire w/Terminal L=220mm BLU	9701169016	
SW101	Side 8SS1012-1	9701426010		(W103)	Wire w/Terminal L=220mm RED	9701170012	

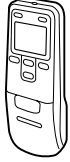
**INDICATOR PCB ASSEMBLY (Ref. No.385)**

Ref. No.	Description	Part No.	Ord. Q'ty
X201	Remote Control Amplifier SBX 1810-22	0101525129	
D201	Diode SLI-343UR RED	0000727518	
D202	Diode SLR-342MG GRN	0000727167	
	Lamp Cover-A	9303702000	
CN201	Wire w/Connector L=250mm	9700923015	
C201	Cap. Ceramic 0.1μF	0300988251	
C202	Cap. Elec. 25V 10μF	0300328026	



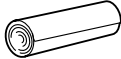

# STANDARD ACCESSORIES

## INDOOR UNIT ACCESSORIES

Name and Shape	Part No.			
	RSW-14CA	RSW-14HA	RSW-17CA	RSW-17HA
Wall hook bracket 	9304093008	9304093008	9304093008	9304093008
Wall cap 	313714296205	313714296205	313714296205	313714296205
Remote control unit 	9356765076 (AR-AB25)	9356765069 (AR-AB24)	9356765076 (AR-AB25)	9356765113 (AR-AB35)
Battery (penlight) 	0600185534	0600185534	0600185534	0600185534
Cable mark 	—————	9301385007	—————	9301385007
Tapping screw (big) ( $\varnothing 4 \times 20$ ) 	301141164200	301141164200	301141164200	301141164200
Tapping screw (small) ( $\varnothing 3 \times 12$ ) 	0700019036	0700019036	0700019036	0700019036
Flange screw ( $\varnothing 4 \times 10$ ) 	9305114009	9305114009	9305114009	9305114009
Remote control unit holder case 	9305642014	9305642014	9305642014	9305642014
Cloth tape 	9308117007	9308117007	9308117007	9308117007
Seal-A 	9304536000	9304536000	9304536000	9304536000

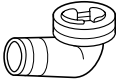

## OUTDOOR UNIT ACCESSORIES

Name and Shape	Part No.			
	ROW-14AA	ROW-14RA	ROW-17CA	ROW-17RB
Hexagon wrench 	301980005800	301980005800	9351228019	9351228019
Drain pipe (Including drain packing) 	_____	9303029015	_____	_____
Drain pipe 	_____	_____	_____	313728031005
Flexible tube 	_____	_____	_____	313013042915
Drain cap 	_____	313166024302	_____	313166024302



MANUFACTURER :

**Fuji Denki Sosetsu Co.,**

Tokyo, Japan



**Большая библиотека технической документации**

<https://splitsystema48.ru/instrukcii-po-ekspluatácii-kondicionerov.html>

**каталоги, инструкции, сервисные мануалы, схемы.**